

THORNYCROFT TK-40

4-cylinders in line 43 bhp @ 2600 r/min

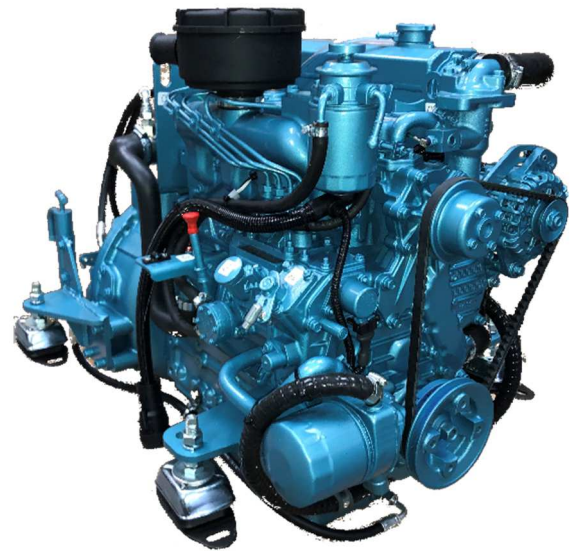

Technical Specifications

Type	Diesel, 4 Stroke
No of cylinders	4, in line
Intake system	Naturally Aspirated
Bore x Stoke	87mm x 92.4mm
Total Displacement	2179 cc
Intermittent power	43 bhp @ 2600 r/min
Continuous power (ISO 8665)	30.4 kW@ 2600 r/min
Injection System	Mechanical and indirect
Starter Motor	12V
Alternator	75A, 12V
Max Operating Angle	30' intermittent / 25' continuous
Rotation (viewed from flywheel)	Counter clockwise
Cooling System	Sea water heat exchanger
Dry Weight without gearbox	256 kg
Seawater inlet hose diameter	27 mm
Fuel feed hose diameter	8 mm
Fuel return hose diameter	5 mm
Exhaust hose diameter	50mm
Emission Compliance	EU RCD2

Engine Control Panel

	Standard – TK1		Deluxe Panel - TK2
	Tachometer		Tachometer
	Hour recorder		Hour recorder
	Keyswitch		Keyswitch
	Low Battery Alarm		Voltmeter
	High Engine Temp		Temperature Gauge
203mm x 165mm	Low Oil Pressure	280mm x 190mm	Oil Pressure Gauge

Scope of Supply

Standard Equipment

Standard Engine Control Panel TK1
 4-metre extension loom
 Anti-Vibration Mounts
 Sump oil drain pump
 Water trap within fuel filter
 Single Side Servicing
 Gear driven Water pump
 Owner's Manual

Optional Equipment

Deluxe Control Panel TK2
 Additional Alternators
 Deck Wash Pump
 Hydraulic Pumps
 Front Power Take off
 Hot Water connections
 Dry exhaust / Keel Cooling (workboat only)
 Water inlet system
 Exhaust Systems
 Fuel intake systems

Engine Drawing

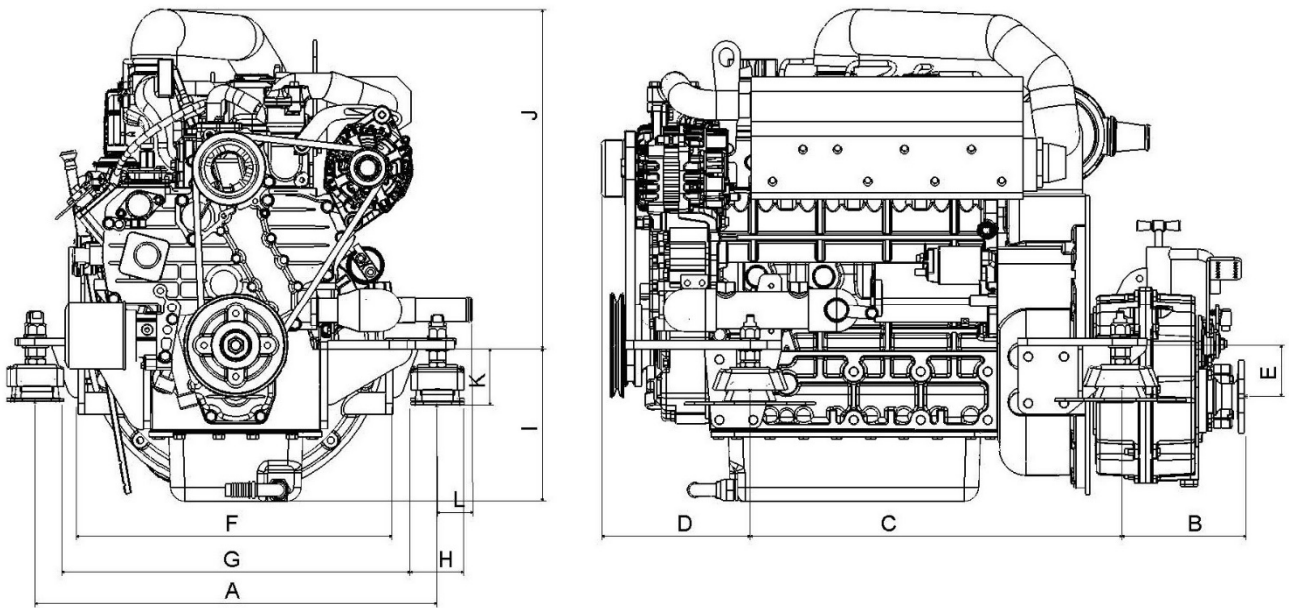

Engine	A	B	C	D	E	F	G	H	I	J	K	L
Thornycroft TK-40	572	185	530	215	69	472	497	75	215	515	80	108

Dimensions are shown for Guidance Only, engine is shown with PRM 150

Gearbox Options

Model	Angle	Ratio (Pleasure)	Ratio (Commercial)	Engine Weight with Gearbox
PRM 125	0°	2.04:1	N/A	277 kg
PRM 150	0°	1.53:1, 2.09:1, 2.82:1	N/A	277 kg
PRM 280	0°	1.96:1, 2.94:1	1.96:1, 2.94:1	304 kg
TMC 345A	8°	1.54:1, 2.00:1, 2.47:1	1.54:1, 2.00:1, 2.47:1	281 kg

Authorised Dealer:

THORNYCROFT

Marine Enterprises Ltd.
 Units 1-3, Townsend Buildings, Melbury
 Osmond, Dorchester. DT2 0LP
 Tel: +44 (0) 1935 83876
 E-mail: info@thornycroftengines.com

Ref: TK-40/200421